



# BOX ERECTOR

## MASTER SERIES MBE-SERIES

The Master MBE-SERIES is a versatile 5 panel box erector for a wide range of boxes and trays. This system erects Higgs fold-over style boxes at a rate of 10-15 boxes per minute. Side flaps can be friction tucked to provide a clean look. The MBE-SERIES will efficiently save space in almost any production or distribution environment.

The MBE-SERIES is manufactured in the USA in accordance with ARPAC's Lean Manufacturing Process (AM<sup>2</sup>) to ensure quality, performance and value.



MBE-1200



MBE-1300

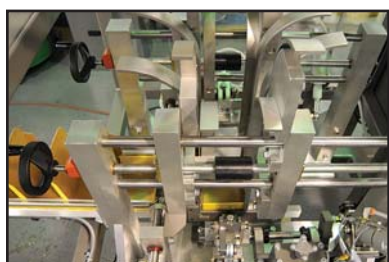

Box Folding Area



User-Friendly Operation Controls



Blank Feed Hopper

## FEATURES

- Heavy-duty rugged construction designed for high durability and around-the-clock operation
- Laser cut and CNC machined components for maximum precision
- Powder coat finish that provides a durable scratch resistant surface and prevents corrosion
- 150 capacity blank feed hopper - easy to load and adjust
- Positive blank control with Venturi vacuum pull-down system
- Box erecting assembly, supported by linear bearings moving on hardened shafts and lead screws
- Tool-less changeovers with scales for setup repeatability
- Electrical control panel with Allen-Bradley® PLC
- Emergency stop on the control panel
- On-demand product release photo sensor

## OPTIONS

- Machines can be customized to handle box sizes outside standard specifications
- Extended outfeed
- Powered magazine up to 500 blank capacity
- Stainless steel construction
- Additional e-stops can be added upon request
- Stack light provides visual indication of machine operating status
- Casters for machine portability
- Spare parts kit
- Preventive maintenance contracts

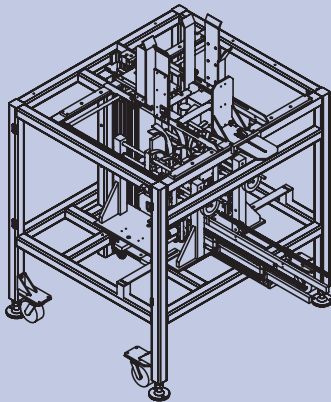

## SPECIFICATIONS

### Speed

- Up to 15 cycles per minute (MBE-1200)
- Up to 12 cycles per minute (MBE-1300)

### Power Requirements

- Electrical: 115VAC, 1Ph, 5A, 60Hz  
Other voltages available on request
- Pneumatic: 80 psi, 1 SCFM per cycle

### Box Sizes\*

Box Sizes	Width	Length	Height
<b>MBE-1200</b>	3"-7"	5"-11"	1.5"-4"
<b>MBE-1300</b>	3"-9"	3"-13"	2"-5"

- Max. blank size: 27"L x 22"W (MBE-1200)
- Max. blank size: 30"L x 25"W (MBE-1300)

\* Other sizes available on request.  
Not all values can be combined.  
Contact factory with blank samples for evaluation and quotation.

