

Packaging Machinery



Hurricane

Hurricane



Example of products.

1 Horizontal flow wrap packaging machine which produces closed wrappers with three sealed edges from a roll of heat-sealable wrapping material.

2 Packaging which is strong, attractive and perfect: the special design of the forming tunnel, the optimum calender and roller device for film transfer and the position of the various component units combine to give a machine which wraps the product perfectly and produces seals which are wrinkle free and positioned correctly.

3 High flexibility and quick format change: Hurricane can package a vast range of regularly shaped, solid products from the food, stationery, chemical and pharmaceutical sectors. It is not necessary to change any mechanical part in order to change the set-up, this is done by using two handwheels which carry out immediate adjustments to the length of the package and the speed of the sealing crimpers.

Optional:

- Date Printer.
- Photocell to register centre-printed wrapping material.
- Dual reel holder.
- Pre-heating of the first set of Fin Wheels: useful for speeds greater than 100 package/min.
- Two Up Sealing Crimper Jaws for use with smaller products and for higher speed.
- Shrink Version.

In addition, for the Electronic version:

- Driven by two brushless motors in electric axis for separate control of the longitudinal and transversal sealing units.
- Adjustment of the bag length by means of an alphanumeric keyboard.
- Automatic print centring in real time.

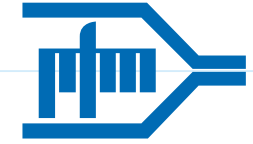

Packaging Machinery

Technical Specifications:

- Conforms to EEC standards.
- 2M long in-feed belt with quick-release, interchangeable pushers.
- 2 hand wheels with numerical reference system for adjusting package length and crimper speed.
- Forming box with adjustable height and width for different sized products.
- 3 pairs of Fin Wheels.
- Self-centering reel holder with reel brake.
- 600mm long motorized discharge belt.



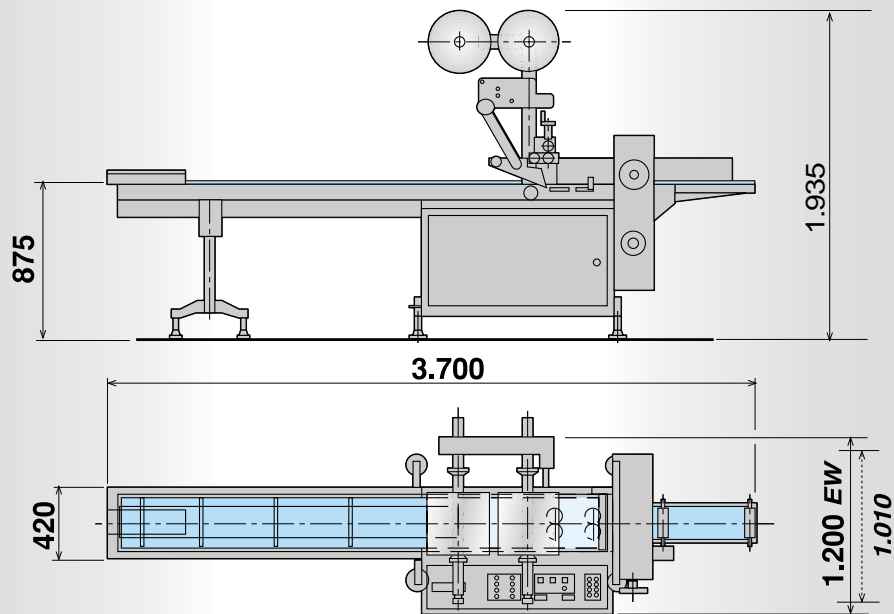

Hurricane Technical Data:

	Hurricane	Hurricane EW
Pack Length:	min. 40, max. 350 mm	min. 40, max 350
Pack width:	min. 5, max 220 mm	min. 5, max 320 mm
Pack height:	up to 100 mm (standard version) 140 mm (special version)	up to 100 mm (standard version) 140 mm (special version)
Reel width:	max 500 mm	max 700 mm
Reel diameter:	max 350	max 350 mm
Width of Sealing Crimper Jaws:	250 mm	350 mm
N° of up Sealing Crimpers Jaws:	1 - 2	1 - 2
Mechanical speed:	up to 100 cycles/min*	up to 100 cycles/min*
Versions:	mechanical	mechanical - electronic
Wrapping material:	PP (laminated or bonded), PE (Poly version) and shrink	PP (laminated or bonded), PE (Poly version) and shrink
Weight:	350 Kg	400 - 350 Kg
Power consumption:	3,5 Kw	3,5 - 5,5 Kw
Voltage:	380V 3phase + neutral + earth 50Hz	380V 3phase + neutral + earth 50Hz

* Depending on product size wrapping material and number of crimpers.

Note : The technical data related to the wrapping speeds and the ones related to the dimensions of the products are calculated considering the variables separately.

As a consequence, the maximum speeds are not reachable with the larger products being the specific wrapping speed determined in function of the dimensions of the specific product. Technical data must be confirmed by PFM.

PFM reserves the right to modify technical data without previous notice.

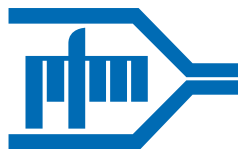

Packaging Machinery

**PFM S.p.A. SEDE CENTRALE
PACKAGING MACHINERY**

ITALIA
Via Pasubio, 49 -
Torrebelvicino (VI) ITALIA

Tel: 0445/570110
Fax: 0445/570175
Telex: 480405
Internet: www.pfm.it
E-mail: pfm@pfm.it

**PFM PACKAGING
MACHINERY LTD**

GREAT BRITAIN
Unit 8/9, Intercity Way
LEEDS LS13 - 4LY

Tel: (+44) -113 -2393401
Fax: (+44) -113 -2393402
E-mail: pfm@pfm-ltd.co.uk

**PFM PACKAGING
MACHINERY
CORPORATION**

USA & CANADA
1271, Ringwell Ave.
Newmarket
Ont. Canada L3Y 7V1.

Tel: (+1) - 905 - 836 - 6709
Fax: (+1) - 905 - 836 - 7763
Internet: www.pfmusa.com
E-mail: info@pfmusa.com

**PFM PACKAGING
MACHINERY LTD**

RUSSIA
UL. BOLSCIAIA NIKITSKAYA,
31, kv.9
103009 MOSCOW

Tel - Fax: (007) (095) 9265086