

HCF SERIES



PACKAGING SOLUTIONS THAT MEAN BUSINESS

HCF SERIES

BOTTOM OVERLAP HORIZONTAL SHRINK WRAPPER
FOR OVERSIZED PRODUCTS

HCF SERIES



Left hand model shown

The HCF SERIES intermittent motion horizontal shrink wrapper is ideal for overwrapping large industrial products where full enclosure is required. Reaching speeds up to 15 packages per minute, the HCF SERIES wrapper operates on-demand as product is placed on the infeed conveyor. Product is then conveyed through a film forming head which engulfs the product in film while creating a bottom overlap seal along the length of the product.

A set of seal bars then creates a cross seal. An optional bottom seal produces positive thermal seal.

The HCF SERIES is available with a variety of optional infeeds to accommodate a wide range of product sizes. An optional HVP4/488 stand-alone shrink tunnel completes the system.



Wrapping Stacks of Corrugated Blanks



Wrapping Rolls of Sod



User-Friendly Operator Controls

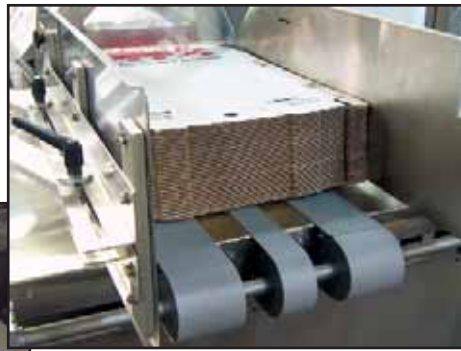

Self-Tracking Conveyor Belts



Side Mounted Dual Film Cradles for Easy Film Loading

APPLICATIONS

- Doors
- Windows
- Ceiling tiles
- Insulation
- Pizza boxes
- Rubber mats



Optional Thermal Bottom Overlap Seal



Pizza Boxes on Seal Conveyor



Film Former



Belted Infeed Conveyor

FEATURES

- Heavy-duty rugged construction designed for high durability and around-the-clock operation
- Laser cut and CNC machined components for maximum precision and strength
- Steel-It paint provides a scratch resistant surface and prevents corrosion
- Allen-Bradley® programmable logic controller with ARPAC standard operator interface stores up to 16 product parameters
- Digital controls ensure fast and accurate setup of conveyor speeds, timing, and temperature settings when changing product size and film
- Self-tracking conveyor belts
- Side mounted dual roll film cradle for easy loading and quick changeovers
- Interchangeable film former system
- Powered variable speed pinch roll film feed system for positive film feed
- NEMA 12 main electrical cabinet and controls
- Adjustable leveling legs
- 1HP variable speed conveyor drive motor
- Plasma coated hot knife seal bar
- Film rack and electrical box can be placed on either side of the machine
- Film forming plow
- Adjustable product infeed side guides
- Quick-change seal jaws
- Seal jaw obstruction sensors

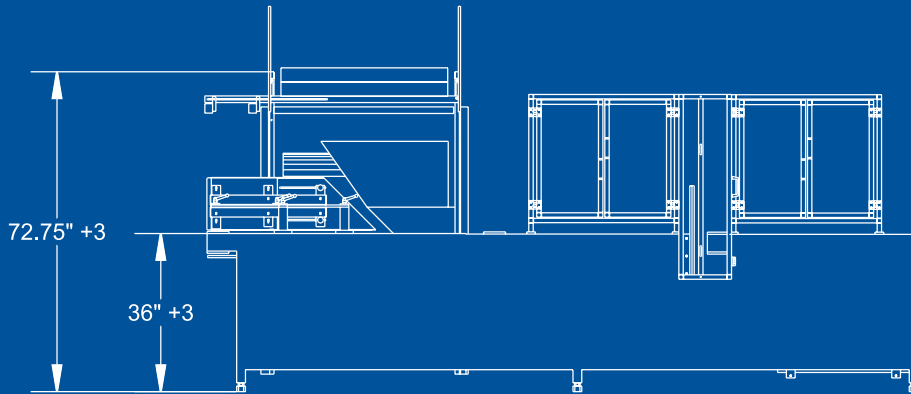
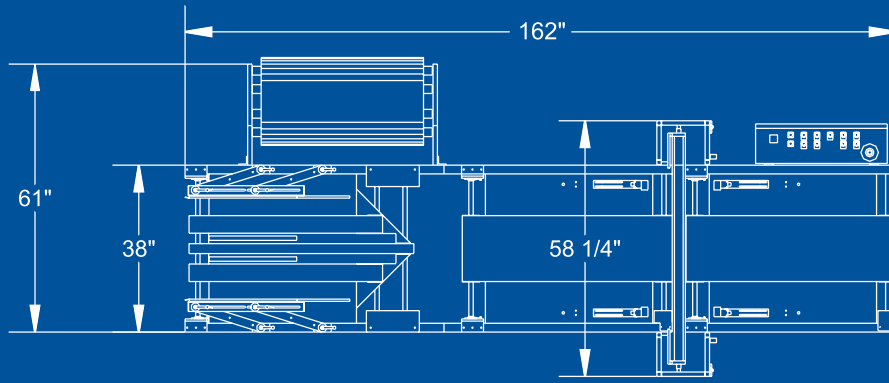

Left hand model shown
opposite hand available on request

SPECIFICATIONS

Speed

- Up to 15 packages per minute (based on product specifications)
- Max. belt speed: 68FPM

Power Requirements

- Electrical: 240V, 3Ph, 60Hz, 14A (HCF37)
480V, 3Ph, 60Hz, 7A (HCF48)
- Pneumatic: 60-80 psi, 5 SCFM

Film

- Max. film width:
37" Centerfolded (HCF37)
48" Centerfolded (HCF48)
- Max. film roll diameter: 20"
- Film type: centerfolded polyolefin, polyethylene or PVC

OPTIONS

- Customizable infeeds and product handling solutions
- Random pneumatic hole punch
- Additional plows
- Accumulation conveyor
- Thermal bottom lap seal
- HVP4/488 solid belt shrink tunnel

Product Sizes	Width (max.)	Length (min.)	Height (max.)
HCF37	27"	8"	16"
HCF48	38"	8"	19"

Note: Specifications and product sizes may vary, depending upon the application.



ARPAC L.P. 9511 West River Street | Schiller Park, IL 60176 USA | P 847 678 9034 | F 847 671 7006 | www.arpac.com

copyright ARPAC L.P. 2006

061606-00