



HC37

CONTINUOUS-MOTION BOTTOM OVERLAP HORIZONTAL SHRINK WRAPPER

The HC37 continuous motion horizontal shrink wrapper is ideal for completely overwrapping individual products and multipacks at speeds up to 80 packages per minute.

This system is used when visually appealing packages are important for retail display. A unique seal frame enables the HC37 to make horizontal as well as vertical cross seals. A static bottom lap seal with vacuum belt minimizes seal lines to better showcase your product.

This heavy-duty system is constructed with a welded tubular steel frame and has powder coat finish. Standard features include: an independently driven 6 ft. flighted infeed conveyor, a user-friendly, color touchscreen operator interface, precision temperature control with a hot knife seal and cut-off, and a self-contained vacuum system.

The HC37 is available with many optional "Quick-Connect" infeeds to accommodate a wider range of package sizes. The HC37 is complete with ARPAC stand-alone shrink tunnels that ensure a uniform shrink.



User-Friendly Operator Controls



Interchangeable Horizontal / Vertical Cross Seal



Film Cradle for Easy Film Loading

FEATURES

- Heavy-duty rugged tubular frame construction designed for high durability and around-the-clock operation
- Laser cut and CNC machined components for maximum precision and strength
- Powder coat finish that provides a durable scratch resistant surface and prevents corrosion
- ARPAC designed rack and pinion seal carriage
- Allen-Bradley® programmable logic controller
- ARPAC operator interface with color touchscreen, message display and self-diagnostics
- Self-contained vacuum system
- Vacuum belt
- Standard horizontal and vertical cross seal
- 8" seal bar opening
- 17" wide seal bar
- Static bottom seal
- Guards and control box doors are electrically interlocked
- Relaxed film tension at cross seal
- Needle wheel film perforator
- Missing product detection
- Low film alert
- NEMA 12 main electrical cabinet and controls
- Central point lubrication simplifies preventive maintenance

OPTIONS

- Variable speed discharge conveyor (for bunching)
- Belted infeed
- Seal jaw bridge
- Extended flighted infeed
- Stainless-steel construction (HCS37)
- Application specific infeeds
- Print registration capability
- Thermal bottom seal
- Static/thermal bottom seal
- Hot air bottom seal (for polyethylene film)
- Easy open film perforation system
- Hole punch
- Paper feeders
- 460VAC, 3PH, 15A
- Variety of "Quick-Connect" infeed systems

SPECIFICATIONS

Speed

- Up to 80 packages per minute
- Up to 90 linear feet per minute

Power Requirements

- Electrical: 230VAC, 1Ph, 22A
- Pneumatic: 80 psi, 10 SCFM

Product Range

Product Size	Width	Length	Height
Seal Bar (Vertical)	7.5" max.	3.5" to infinite*	9" max.
Seal Bar (Horizontal)	16" max.	3.5" to infinite*	7.5" max.

Specifications and product sizes may vary, depending upon the application.

* 3.5" or less with optional seal jaw bridge

Film

- Max. film width: 37" single-wound
- Max. film roll diameter: 14"
- Seal bar width: 17"
- Film type: polyolefin, PVC or polyethylene

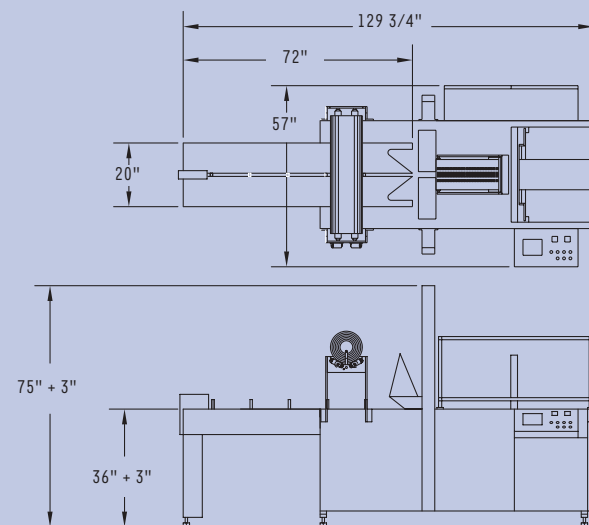

APPLICATIONS

- Multipacks
- Mailers
- Cosmetics
- Games
- Spray cans
- Print applications
- Food products
- Light bulbs
- Paper products



ARPAC L.P. 9511 West River Street | Schiller Park, IL 60176 USA | P 847 678 9034 | F 847 671 7006 | www.arpac.com

copyright ARPAC L.P. 2008