

WULFTEC® WRING-500

AUTOMATIC ROTARY RING WRAPPER



Up To 120 Loads PER HOUR

CRAFTED FOR SUCCESS

For increased productivity, this quality engineered stretch wrapper features:

- High-speed wrapping for increased productivity
- Versatility with different wrap patterns
- Film savings with one way wrapping
- Banding and split wrap capabilities
- Carbon fiber ring - lighter, more resistant, best response to speed change
- Bluetooth technology for reduced maintenance

THE WULFTEC ENGINEERING TEAM HAS REDEFINED THE BOUNDARIES OF ROTARY RING WRAPPERS



Infrared film tail seaming device ensures a full width seal



NO-THREAD® powered pre-stretch carriage with tilting film mandrel allowing fast and easy film loading



Counterweight system for smooth operation without vibration, resulting in a safer operation



Horizontal and vertical ring guiding by self aligning and maintenance free polyurethane wheels

PRODUCTIVITY

HIGH SPEED

VERSATILITY

FILM SAVINGS

THE WULFTEC PROMISE

Having a Wulftec® stretch wrapping machine on the production line is a powerful statement. It's an investment in strong values, because Wulftec is dedicated to manufacturing only the best. It's an investment in all-steel construction, for increased stability and strength. It's an investment in success, because Wulftec® equipment is designed and built to wrap load after load...year after year.



WE FEAR NO PACKAGING CHALLENGE

WWW.WULFTEC.COM

TECHNICAL SPECIFICATIONS

PRODUCTION RATE*	- Up to 120 loads per hour
LOAD SIZE **	- Min.: 36" W x 36" L x 24" H - Max.: 48" W x 50" L x 80" H (maximum load diagonal 70")
LOAD WEIGHT	- 5,000 lbs (6,000 lbs option)
MACHINE DIMENSIONS***	- 108" W x 145" L x 162" H
ELECTRICAL REQUIREMENTS	- 460/3/60 20 A
PNEUMATIC REQUIREMENTS	- 3 CFM @ 80 PSI comes with FR (Filter, Regulator)
FILM DELIVERY SYSTEM	- 20" NO-THREAD® Powered Pre-Stretch Carriage - Tilting film mandrel for ease of film loading - 2.2 HP AC motor with Allen Bradley variable frequency drive - 50-300% pre-stretch - Electronic film tension control with analog sensor - Film force release for easy pull at start and end of cycle - Sensing device for film out/broken with visual alarm - Bluetooth technology for interference free operation
FILM TAIL TREATMENT	- Automatic pneumatic film clamping device - Infrared film tail seaming device
RING ROTATION DRIVE	- 3 HP AC motor with variable frequency drive - Electromechanical brake
RING FRAME	- 108" outside diameter including carriage - Carbon fiber ring construction - Aluminum and steel frame construction - Supported by ACLA wheel bearings - Upper and lower ring limit position
CONVEYORS	- Heavy-duty flange-mounted bearings - 2 1/2" dia. rollers on 3" centers - 52" BFR (between frame rails)
FRAME CONSTRUCTION	- Welded structural steel construction - Free standing integrated leg design - Heavy duty safety fencing with one interlocked access door enclosing the wrapping zone - Easy access to all components
WARRANTY	- 3-year unlimited cycle warranty - 10-year warranty on steel structure - Lifetime warranty on pre-stretch rollers' blue compound

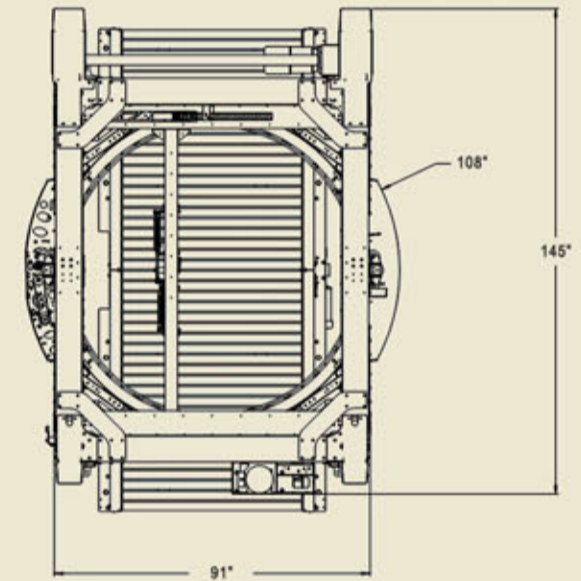
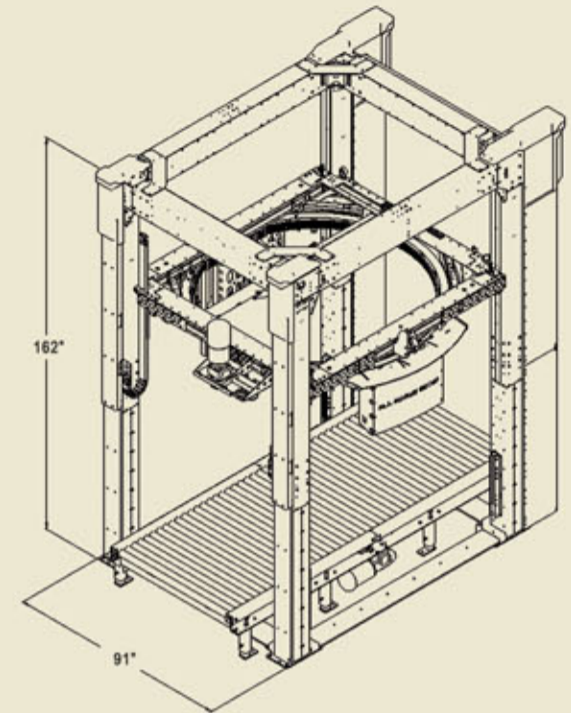

OPTIONS AVAILABLE

- Top platen
- Top sheet dispenser
- Top sheet blow-down coronet
- Infeed conveyors
- Outfeed conveyors
- Right angle transfers
- Pallet lifts



Reduced energy usage by throughput anticipation on automatic machines: Machine will operate at a lower speed when the throughput from the line is slower and speedup to allow production bursts. For an average production line† the energy savings would equal 20 x 40W lamps lit for 6 hours.

Reduced film waste by optimized resolution: Machine will use a higher resolution positioning system to deliver the film in a more accurate quantity. This means an average film reduction of 4 feet of film per pallet when compared to other control systems. That's 60 miles† of unstretched film per year.

Reduced general waste by better product protection for handling and transport: With very low wrap possibility, the product is properly secured to the pallet, resulting in a pallet that is more stable for transport, and therefore less damage.

By using VFD on all motors, this ensures that only the power required by the load is used, regardless of the HP of the motor.

* PRODUCTION RATE BASED ON LOAD AND MACHINE SIZE AND CONFIGURATION
 ** OTHER WRAP HEIGHTS AVAILABLE
 *** OVERALL DIMENSIONS OF MACHINE IN OPERATION
 † BASED ON A PRODUCTION RATE OF 60 PALLETS PER HOUR, 2 SHIFTS, WHERE 50% OF THE PRODUCTION IS IN "PEAK-MODE", 250% PRE-STRETCH
 ALL MACHINE SPECIFICATIONS ARE SUBJECT TO CHANGE WITHOUT PRIOR NOTICE / NOMINAL DIMENSIONS SHOWN

